

CHANGES IN FORCE: C1 AND C3

TB 9-6625-059-35

*CHANGE 3

DEPARTMENT OF THE ARMY TECHNICAL BULLETIN

CALIBRATION PROCEDURE FOR OSCILLOSCOPE

**AN/USM-184 (TEKTRONIX TYPE 545A),
AN/USM-196 AND OS-159(P)/USM-195
(TEKTRONIX RM45A AND LAVOIE MODEL LA265A)**

Headquarters, Department of the Army, Washington, DC
9 March 1979

TB 9-6625-059-35, 15 March 1976, is changed as follows:

Page 13, paragraph 17a(4), line 4. "+1.5 is changed to ± 1.5 ."

Paragraph 17a(5), line 6. " ± 1.5 divisions" is changed to " ± 1.5 minor divisions."

Page 14, paragraph 18a. Subparagraph (7) is superseded as follows:

(7) Repeat technique of **(2) above for TI and time-mark generator switch settings and indications** listed in table 6. At each setting, align second (1/cm) or third (2/cm) marker behind second vertical graticule line. At each setting, if either 10th (1/cm) or 19th (2/cm) markers are not displayed within ± 1.5 minor divisions of 10th vertical graticule line, perform adjustments listed in table 6.

Page 15, paragraph 21a(4), line 2. "TI" is changed to "test oscilloscope."

Page 16. Paragraph 25b is superseded as follows:

b. In accordance with TM 38-750, annotate and affix DA Label 80 (US Army Calibrated Instrument). When the TI receives limited or special calibration, annotate and affix DA Label 163 (US Army Limited or Special Calibration). When the TI cannot be adjusted within tolerance, annotate and affix DA Form 2417 (US Army Calibration System Rejected Instrument).

By Order of the Secretary of the Army:

BERNARD W. ROGERS
General, United States Army
Chief of Staff

Official:

J. C. PENNINGTON
Major General, United States Army
The Adjutant General

Distribution:

To be distributed in accordance with DA Form 12-34A, requirements for Calibration Procedures Publications.

US GOVERNMENT PRINTING OFFICE: 1979-665-012/1463

PIN NO: 010304-003

*This change supersedes Change 2, 27 September 1976.

TB 9-6625-059-35

CHANGE 1

DEPARTMENT OF THE ARMY TECHNICAL BULLETIN

CALIBRATION PROCEDURE FOR OSCILLOSCOPE AN/USM-184 (TEKTRONIX, TYPE 545A), AN/USM-196, AND OS-159(P)/USM-195 (TEKTRONIX, TYPE RM45A AND LAVOIE MODEL LA265A)

Headquarters, Department of the Army, Washington, DC
20 August 1976

TB 9-6625-059-35, 15 March 1976, is changed as follows:

Page 8, paragraph 8a(4) is superseded as follows:

(4) Vary autotransformer (A2) between 105 and 125 V and back to 115V. Vertical amplitude on TI crt will remain at 4 major divisions ± 1 minor division.

Page 12, paragraph 13a(1) Add subparagraph (1.1) as follows:

(1.1) Connect TI CAL OUT to calibration adapter (A3) EXT INPUT, using adapter and cable (B2 and B5).

Page 15. "Table 5" is changed to "Table 6."

By Order of the Secretary of the Army:

FRED C. WEYAND
General, United States Army
Chief of Staff

Official:

PAUL T. SMITH
Major General, United States Army
The Adjutant General

Distribution:

To be distributed in accordance with DA Form 12-34A, requirements for calibration procedures publications.

US GOVERNMENT PRINTING OFFICE: 1976 - - 665668/791

PIN: 010304-001

***TB 9-6625-059-35**

DEPARTMENT OF THE ARMY TECHNICAL BULLETIN

CALIBRATION PROCEDURE FOR OSCILLOSCOPE, AN/USM-184 (TEKTRONIX TYPE 545A) AN/USM-196 AND OS-159 (P)/USM-195 (TEKTRONIX TYPE RM45A AND LAVOIE MODEL LA265A)

Headquarters, Department of the Army, Washington, DC
15 March 1976

REPORTING OF ERRORS

You can help improve this publication by calling attention to errors and by recommending improvements and stating your reasons for the recommendations. Your letter or DA Form 2028, Recommended Changes to Publications, should be mailed directly to Commander, U.S. Army Aviation and Missile Command, ATTN: AMSAM-TMD-EP, Redstone Arsenal, AL 35898-5000. FAX to DSN 788-2313 (commercial 256-842-2313). A reply will be furnished directly to you.

		Paragraph	Page
SECTION	I.	IDENTIFICATION AND DESCRIPTION	
		Test instrument identification.....	1 2
		Calibration data card, DA Form 2416	2 2
		Calibration description	3 4
	II.	EQUIPMENT REQUIREMENTS	
		Equipment required.....	4 4
		Accessories required	5 4
	III.	PRELIMINARY OPERATIONS	
		Preliminary instructions.....	6 5
		Equipment Setup.....	7 6
	IV.	CALIBRATION PROCESS	
		Vertical gain and stability	8 7
		Amplitude calibrator.....	9 8

*This bulletin supersedes TB 9-6625-059-35, 25 February 1972, including all changes.

	Paragraph	Page
Crt alignment	10	9
Crt geometry	11	10
Trigger A.....	12	11
Trigger B.....	13	14
5X magnifier gain and sweep registration.....	14	16
External horizontal dc balance and deflection factor	15	17
External horizontal input compensation	16	18
Time base B sweep rate	17	18
Time base A sweep rate	18	20
Time base A sweep length	19	21
Time base B sweep length	20	21
Lockout level.....	21	22
Delay start and delay stop.....	22	22
Rise time	23	23
Power supply.....	24	24
Final procedure.....	25	24

**SECTION I
IDENTIFICATION AND DESCRIPTION**

1. Test Instrument Identification. This bulletin provides instructions for the A- and C-level calibration of Oscilloscope AN/USM-184 (Tektronix Type 545A), AN/USM-196 and OS-159(P)/USM-195 (Tektronix Type RM45A and Lavoie Model LA265A). The manufacturers' instruction manuals were used as the prime data source in compiling these instructions. The oscilloscope will be referred to as the "TI" (test instrument) throughout this bulletin.

a. Model Variations. AN/USM-184 is the military designation for Tektronix Type RM45A, which is the same as type 545A when turned 900; AN/USM-196 is the same as type 545A. All models are electrically the same.

b. Time and Technique. The time required for this calibration is approximately 5 hours, using the dc and low frequency technique.

2. Calibration Data Card, DA Form 2416

a. Forms, records, and reports required for calibration personnel at all levels are prescribed by TM 38-750. DA Form 2416 must be annotated in accordance with TM 38-750 for each calibration performed.

b. Adjustments to be reported on DA Form 2416 are designated (R) at the end of the sentence in which they appear. When adjustments are in tables, the (R) will follow the designated adjustment. Report only those adjustments made and designated with (R).

TB 9-6625-059-3

3. Calibration Description. TI parameters and performance specifications which pertain to this calibration are listed in table 1.

Table 1. Calibration Description

Test instrument parameters	Performance specifications
Power input requirements ¹	105 to 125 or 210 to 250 vac, 50 to 60 Hz
Vertical deflection	Main frame amplifier 0.1 v p-p/cm; bandpass dc to 30 MHz (down 3 db \pm 1/2 db at 30 MHz), using type K plug-in; rise time 0.012 μ sec.
Triggering modes	TIME BASE A: automatic, ac, dc, ac low-frequency reject, and high-frequency sync. TIME BASE B: automatic, ac, and dc
Triggering signals	Internal signal producing 2 mm of vertical deflection. External signal of 0.2 to 10 v. High-frequency sync; internal signal producing 2 cm of vertical deflection or external signal of more than 2 v.
Sweep range	TIME BASE A continuously variable from 0.1 μ sec/cm to 5 sec/cm. Accuracy \pm 3% in 24 calibrated steps. TIME BASE B continuously variable from 2 μ sec/cm to 1 sec/cm. Accuracy \pm 3% in 18 calibrated steps. Magnifies center 2-cm portion of crt display (extends TIME BASE A sweep range to 0.02 μ sec/cm and TIME BASE B sweep range to 0.4 μ sec/cm).
External horizontal input	Deflection factor continuously variable from 0.2 to 15 v/cm (approx.). Frequency response dc to 240 kHz (3 db down at 240 kHz). Input characteristics, 1 megohm paralleled by approx. 55 μ F. Delayed sweep continuously variable from 1 μ sec to 10 sec. Actual delay accuracy \pm 1% of indicated delay from 2 μ sec/cm to 0.1 section; within 3% from 0.2 to 1 sec/cm. Incremental delay accuracy \pm 0.2%. Amplitude calibrator output 1000-Hz square waves from 0.2 mv p-p to 100 v p-p in 18 steps; accuracy \pm 3%.
Output waveforms	Delayed trigger pulse 5-v amplitude (approx.) at end of delay period. Positive gate B, 20-v p-p amplitude (approx.) with same duration as sweep B. Positive gate A, 20-v p-p amplitude (approx.) with same duration as sweep A. Sawtooth A, 150-v peak amplitude (approx.) sweep A sawtooth waveform. Vertical signal output, from vertical deflection system.

¹This specification is for information only and is not necessarily verified in this bulletin.

**SECTION II
EQUIPMENT REQUIREMENTS**

4. Equipment Required. Table 2 identifies the specific equipment used in this calibration procedure. This equipment is issued with secondary transfer standards calibration sets NSN 6695-00-621-7877, AN/GSM-256 (NSN 4931-00-525-8175), and AN/TSM-55 and are to be used in performing this procedure. Alternate items may be used by the calibrating activity when the equipment listed in table 2 is not available. The items selected must be verified to perform satisfactorily prior to use and must bear evidence of current calibration. The equipment must meet or exceed the minimum use specifications listed in table 2. The accuracies listed in table 2 provide a four-to-one accuracy ratio between the standard and TI. Where the four-to-one ratio cannot be met, the actual accuracy, of the equipment selected is shown in parenthesis.

5. Accessories Required. The accessories listed in table 3 are issued with secondary transfer standards calibration sets NSN 6695-00-621-7877 AN/GSM-256 (NSN 4931-00-525-8175), and AN/TSM-55 and are to be used in this calibration procedure. When necessary, these items may be substituted by equivalent unless specifically prohibited.

Table 2. Minimum Specifications of Equipment Required

Item	Common name	Minimum use specifications	Manufacturer, model, and part number (NSN)		
			A-Level	AN/TSM-55	AN/GSM-256
A1	AC/DC VOLTMETER	Range: -1375 to +510 vdc. Accuracy: ±0.75%	Dana, Model 5703-S-2127 (7912606) w/HV probe (7913350)	J-Omega, Model 217 (6625-00-935-1425)	Hewlett-Packard Model 3490A OPT 060 (6625-00-557-8305) w/HV probe, K24-3490A (6625-00-107-3853)
A2	AUTOTRANSFORMER	Range: 105 to 125 vac Accuracy: ±0.75%	General Radio, Model W10MT3A-S3 (7910809)	General Radio, Model W10MT3A (6120-00-054-7794)	General Radio, Model W10MT3A (7910809)
A3	CALIBRATION ADAPTER	Rise time: Less than 12 nsec	Tektronix, Type 067-0521-01 (MIS-10258)	Tektronix, Type 067-0521-01	Tektronix, Type 067-0521-01 (MIS-10258)
A4	TIME-MARK GENERATOR	Range: 50-nsec to 5-sec markers	Tektronix, Type 184A MOD146B (7912042-2)	Tektronix, Type 184 (7912042-2)	Tektronix, Type 2901 (7910242-2)
A5	TEST OSCILLATOR	Range: 4 cm	Tektronix, Type RMS561 A MOD 171 (7910655-4) w/plug-ins 3 A6 (7911441-1) and 3B4 (7912040-1)	Hewlett-Packard, Model 130 (AN/USM-254)	Hewlett-Packard, Model 180D (6625-00-022-8228) w/plug-ins 1805A (6625-00-777-3083) and 1825A (6625-00-022-8244)

TB 9-6625-059-3

Table 2. Minimum Specifications of Equipment Required - Continued

Item	Common name	Minimum use specifications	Manufacturer, model, and part number (NSN)		
			A-Level	AN/TSM-55	AN/GSM-256
A6	SQUARE-WAVE GENERATOR	Range: 1 kHz	Tektronix, Type 106 (MIS-10284-1)	Fairchild, Model 791	Hewlett-Packard, Model 211B (6625-00-212-7365)
A7	VOLTAGE STANDARD	Range: .0707 to 36.41 v rms at 1 kHz. Accuracy: +0.75%	Hewlett-Packard Model 745A-C90 (MIS 10342) Type 1	John Fluke, Model 760A (6625-00-935-7002)	John Fluke, Model 760A (6625-00-935-7002)

Table 3. Accessories Required

Item	Common name (official nomenclature)	Description (part number)
B1	ADAPTER ¹	Single banana jack to alligator clip (red) (7907556)
B2	ADAPTER	BNC jack to UHF plug (10519439)
B3	ADAPTER ¹	BNC plug to double banana jack (UG-1441U)
B4	ADAPTER	BNC T type, 2 jacks, 1 plug (MS35173-274C)
B5	CABLE ¹	30-in, RG-58/U; BNC plug terminations (7907467)
B6	CABLE	36-in., RG-58/U; BNC plug and double banana plug terminations (7907471)
B7	LEAD ¹	24-in., No. 18 AWG; single banana plug terminations (7907498)
B8	PROBE	Cable assembly test probe (7911305)

¹Two required.

**SECTION III
PRELIMINARY OPERATIONS**

6. Preliminary Instructions

a. The instructions outlined in this section are preparatory to the calibration process. Personnel should become familiar with the entire bulletin before beginning the calibration.

b. Items of equipment used in this procedure are referenced within the text by common name and item identification number as listed in tables 2 and 3. For the identification of equipment referenced by item numbers prefixed with A, see table 2; for prefix B, see table 3.

WARNING

HIGH VOLTAGE is used during the performance of this calibration. DEATH ON CONTACT may result if personnel fail to observe safety precautions.

7. Equipment Setup

- a.** Remove protective covers from TI and replace upon completion of adjustments.
- b.** Install calibration adapter (A3) in TI.
- c.** Connect TI to autotransformer (A2) and adjust autotransformer controls for a 115-volt ac output
- d.** Energize equipment and allow at least 15 minutes for warm-up.
- e.** Position TI controls as listed in (1) through (10) below:
 - (1) INTENSITY control to midrange.
 - (2) HORIZONTAL DISPLAY switch to A and 5X MAGNIFIER to OFF.
 - (3) A and B TRIGGERING MODE switches to AC.
 - (4) A and B TRIGGER SLOPE switches to +INT.
 - (5) A and B STABILITY controls fully clockwise.
 - (6) A and B TIME/CM switches to .5 MILLISEC.
 - (7) B LENGTH control fully clockwise.
 - (8) VARIABLE control to CALIBRATED (fully clockwise).
 - (9) AMPLITUDE CALIBRATOR switch to OFF.
 - (10) DELAY TIME MULTIPLIER control to 1.0.
- f.** Turn calibration adapter AMPLITUDE control fully clockwise.
- g.** Check rear panel to insure that metal strap between EXTERNAL crt CATHODE and GROUND binding post is in place. Crt CATHODE SELECTOR switch should be positioned away from DUAL TRACE CHOPPED BLANKING position.

**SECTION IV
CALIBRATION PROCESS**

NOTE

Unless otherwise specified, verify the results of each test and take corrective action whenever the test requirement is not met before continuing with the calibration. When indications specified in paragraphs **8** through **23** are not within tolerance, perform the power supply check prior to making adjustments. After adjustments are made, repeat paragraphs **8** through **23**. Do not perform power supply check if all other parameters are within tolerance.

TB 9-6625-059-3

8. Vertical Gain and Stability

a. Performance Check

(1) Connect voltage standard (A7) output to calibration adapter (A3) EXT INPUT, using cable (B6).

(2) Turn calibration adapter test function switch to GAIN SET.

(3) Adjust voltage standard frequency to 1 kHz and output for 4 major divisions of vertical deflection on TI crt. If voltage standard does not indicate between 34.29 and 36.41 volts rms, perform **b** below.

(4) Vary autotransformer (A2) between 105 and 125 volts and back to 115 volts. Vertical amplitude on TI crt will remain at 4 major divisions ± 1 minor division.

b. Adjustments

(1) Adjust voltage standard output for 35.35 volts rms.

(2) Adjust R1027 (fig. 1) until TI crt indicates 4 divisions of vertical deflection (R).

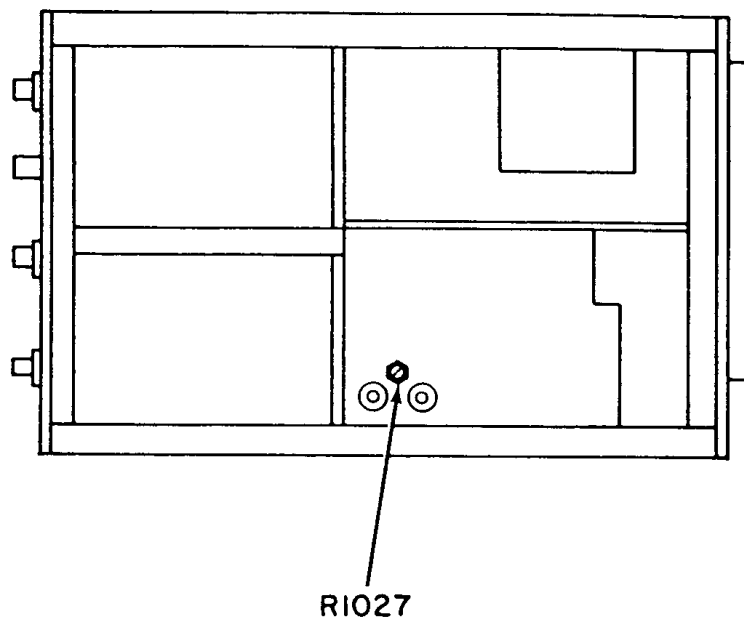

Figure 1. Oscilloscope - bottom view (545A), left view (RM45A).

9. Amplitude Calibrator

a. Performance Check

(1) Turn TI POWER switch to off position (down) and remove tube V875 (fig. 2) from TI.

(2) Turn TI POWER switch to ON.

(3) Connect ac/dc voltmeter (A1) between TI CAL OUT connector and chassis ground using two leads (B7).

(4) Turn TI AMPLITUDE CALIBRATOR to 100 VOLTS. If ac/dc voltmeter does not indicate between 97 and 103 volts dc, adjust CAL ADJ R879 (fig. 2) until ac/dc voltmeter indicates 100 volts dc (R).

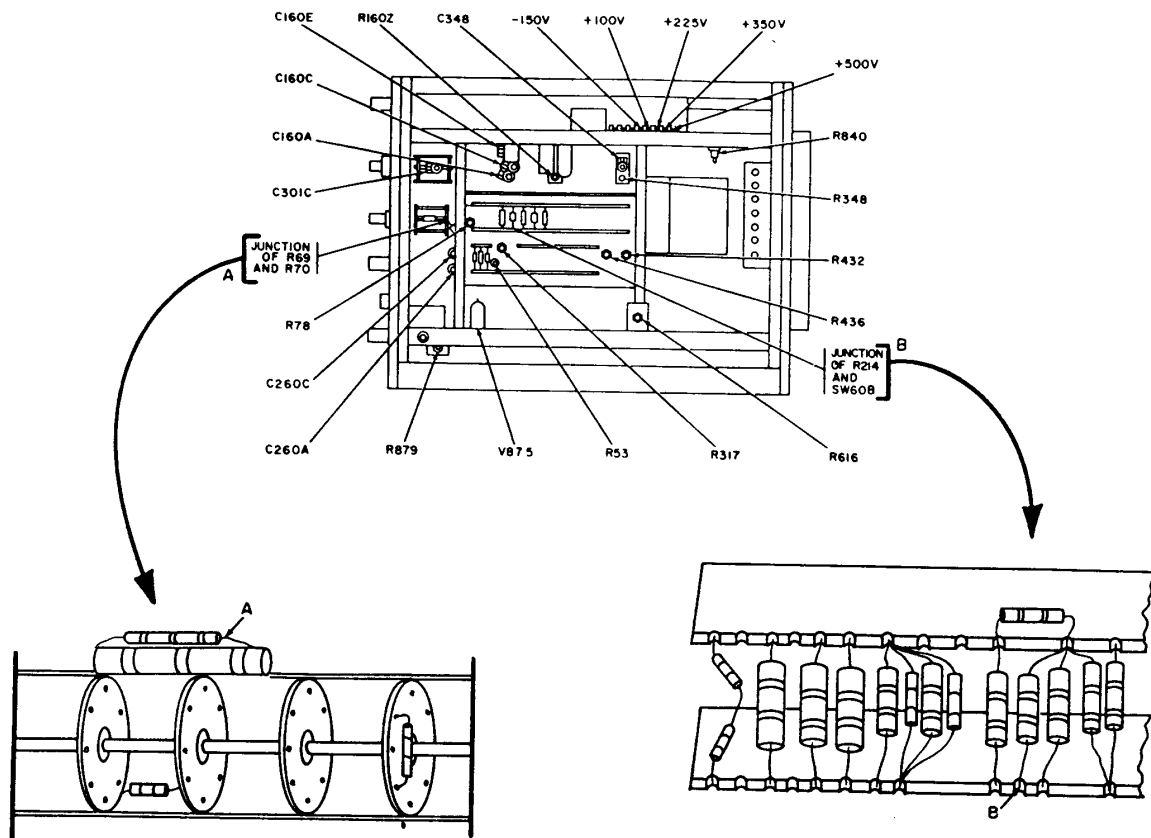

Figure 2. Oscilloscope - right side view (454A), bottom view (RM45A).

TB 9-6625-059-3

(5) Repeat technique of (4) above for TI AMPLITUDE CALIBRATOR switch settings and indications listed in table 4. ac/dc voltmeter will indicate within limits specified.

Table 4. Calibration Accuracy

Test instrument AMPLITUDE CALIBRATOR switch settings	Ac/dc voltmeter indications (V dc)	
	Min	Max
50 VOLTS	48.5	51.5
20 VOLTS	19.4	20.6
10 VOLTS	9.7	10.3
5 VOLTS	4.85	5.15
2 VOLTS	1.94	2.06
1 VOLT	0.97	1.03
.5 VOLT	0.485	0.515
.2 VOLT	0.194	0.206
.1 VOLT	0.097	0.103

(6) Turn TI POWER switch to off position (down) and replace tube V875.

(7) Turn TI POWER switch to ON.

b. Adjustments. No further adjustments can be made.

10. Crt Alignment

a. Performance Check

(1) Adjust TI INTENSITY and A STABILITY controls until trace is visible.

(2) Adjust TI FOCUS and ASTIGMATISM controls for sharpest trace.

(3) Adjust TI VERTICAL POSITION control until trace is aligned on horizontal graticule centerline. If trace does not coincide with horizontal graticule centerline, perform **b** below.

b. Adjustments

(1) Turn red knob located on crt base clamp (fig. 3) until trace is aligned with center graticule line over entire length of crt.

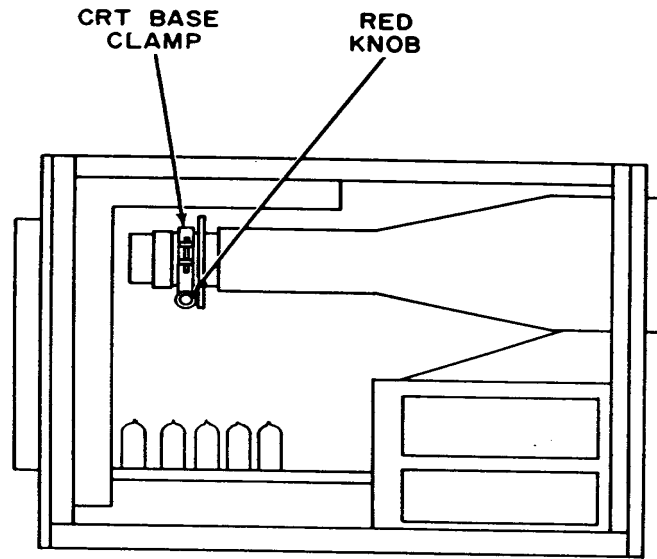

Figure 3. Oscilloscope - left side new (545A), top view (RM45A).

NOTE

Some models have a white lever instead of a red knob. For models not having the red knob, perform (2) through (4) below.

- (2) Loosen crt base clamp.
- (3) Rotate crt until trace and center horizontal graticule are aligned.
- (4) Push crt forward and tighten crt base clamp.

11. Crt Geometry

a. Performance Check

(1) Connect TI CAL OUT to calibration adapter (A3) EXT INPUT using adapter and cable (B2 and B5).

(2) Turn TI AMPLITUDE CALIBRATOR switch to 10 VOLTS and calibration adapter TEST FUNCTION switch to LOW LOAD.

(3) Adjust TI FOCUS, INTENSITY, and ASTIGMATISM controls for best presentation.

(4) Adjust TI STABILITY and TRIGGERING LEVEL controls and calibration adapter VARIABLE control for stable square-wave display.

TB 9-6625-059-3

(5) Adjust TI HORIZONTAL and VERTICAL POSITION controls to align display with vertical graticule lines and calibration adapter VARIABLE control until rising and falling portion of display are visible. If vertical lines are not straight, perform **b** below.

b. Adjustments. Adjust GEOMETRY R861 (fig. 4) for minimum curvature of vertical lines.

12. Trigger A

a. Performance Check

NOTE

TI controls called out in this check refer to TIME BASE A.

(1) Turn TI TRIGGERING LEVEL control to zero and AMPLITUDE CALIBRATOR switch to .5 VOLT.

(2) Turn calibration adapter (A3) VARIABLE control for 1 minor vertical division of display on TI crt.

(3) Adjust TI STABILITY control for stable waveform Center waveform vertically with VERTICAL POSITION control and adjust INTENSITY, FOCUS, and ASTIGMATISM controls for best definition.

NOTE

It may not be possible to obtain a stable waveform at this point.
In either case, perform (4) below

(4) Connect junction of R19 and R20 (fig. 4) to chassis ground, using lead and adapter (B7 and B1).

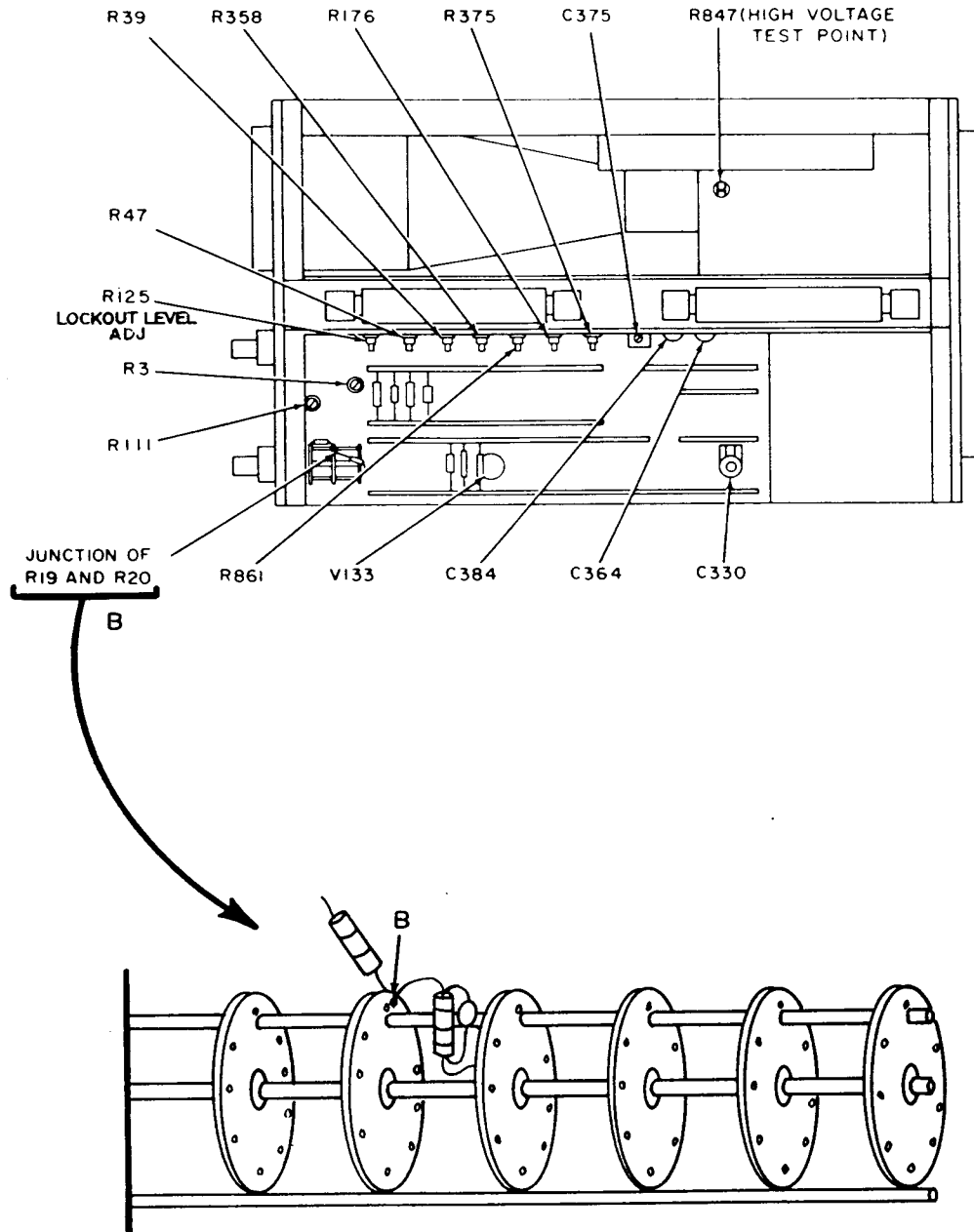

Figure 4. Oscilloscope - top view (545A) and right side RM45A.

(5) While observing waveform, turn TI TRIGGER SLOPE switch from +INT to -INT and back to +INT waveform will invert and remain stable.

NOTE

Perform (6) through (10) below only if stable waveform cannot be obtained in both +INT and -INT positions.

(6) Turn TI TRIG SENS R47 (fig. 4) control fully counterclockwise and TRIG LEVEL CENTERING R39 (fig. 4) control fully clockwise.

(7) Turn TI STABILITY control counterclockwise until waveform just disappears and then two or three degrees farther.

(8) Turn TI TRIG LEVEL CENTERING R39 counterclockwise until waveform reappears. If waveform does not reappear, turn TRIG SENS R47 clockwise a few degrees and readjust R39 until waveform appears.

(9) Turn TI TRIGGER SLOPE switch from +INT to -INT and back to +INT. Adjust TRIG LEVEL CENTERING R39 and TRIG SENS R47 to obtain a stable waveform in both positions.

NOTE

It may be necessary to adjust VERTICAL POSITION control to center display on TI crt.

(10) Turn TI TRIGGERING MODE switch to DC and calibration adapter VARIABLE control for 3 minor divisions of crt display.

(11) Turn TI TRIGGER SLOPE switch from +INT to -INT and back to +INT. If waveform does not invert and remain stable in both positions adjust INT TRIG DC LEVEL R3 (fig. 4) until stable waveform is obtained.

(12) Remove lead and adapter grounding the junction of R19 and R21

(13) Turn TI TRIGGERING LEVEL control until waveform is stable. If white dot on TRIGGERING LEVEL control does not point to zero (0), loosen setscrew on TRIGGERING LEVEL control and turn knob until white dot is aligned.

(14) Tighten setscrew and remove connection to calibration adapter INPUT.

(15) Position TI controls as listed in **(a)** through **(c)** below:

(a) TRIGGERING MODE switch to AUTO.

(b) TRIGGER SLOPE switch to +LINE.

(c) STABILITY control to PRESET.

(16) Connect ac/dc voltmeter (A1) between TI PRESET ADJUST wiper arm R111 (fig. 4) and chassis ground, using leads supplied with (A1) or two adapters and two leads (B1 and B7).

(17) Turn TI PRESET ADJUST fully counterclockwise and then slowly clockwise until trace just appears. Record ac/dc voltmeter indication.

(18) Turn TI PRESET ADJUST control clockwise a few degrees farther until trace brightens. Record ac/dc voltmeter indication.

(19) Turn TI PRESET ADJUST control to obtain an indication on ac/dc voltmeter midway between indications recorded in (17) and (18) above.

b. Adjustments. No further adjustments can be made.

13. Trigger B

a. Performance Check

NOTE

TI controls called out in this check refer to TIME BASE B.

(1) Turn TI TRIGGERING LEVEL control to zero and HORIZONTAL DISPLAY switch to B.

(1.1) Connect TI CAL OUT to calibration adapter (A3) EXT INPUT, using adapter and cable (B2 and B5).

(2) Adjust calibration adapter (A3) VARIABLE control for 1 minor vertical division of display on TI, crt. (If necessary, adjust TI INTENSITY control for a visible trace.)

(3) Adjust TI STABILITY control for stable display. Center waveform vertically with VERTICAL POSITION control and adjust INTENSITY, FOCUS, and ASTIGMATISM controls for best definition.

NOTE

It may not be possible to obtain a stable waveform at this point.
In either case, perform (4) below.

(4) Connect junction of R69 and R70 (fig. 2) to chassis ground, using lead and adapter (B7 and B1).

(5) Turn TI TRIGGER SLOPE switch from +INT to -INT and back to +INT while observing crt waveform. waveform will invert and remain stable.

NOTE

Perform (6) through (9) below only if stable waveform cannot be obtained in both +INT and -INT positions.

(6) Turn TI TRIG LEVEL CENTERING control R78 (fig. 2) fully clockwise and STABILITY control counterclockwise until waveform just disappears; then, turn two or three degrees farther.

(7) Turn TI TRIG LEVEL CENTERING control R78 counterclockwise until waveform reappears.

(8) Turn TI TRIGGER SLOPE switch from +INT to -INT and back to +INT. Adjust TRIG LEVEL CENTERING control R78 to obtain a stable waveform in both positions.

(9) Turn TI STABILITY control fully clockwise and TRIGGERING MODE switch to DC.

(10) Adjust calibration adapter VARIABLE control for 3 minor divisions of display on TI crt.

NOTE

It may be necessary to adjust VERTICAL POSITION control to center display on TI crt.

(11) Adjust TI STABILITY control for stable display.

(12) Turn TI TRIGGER SLOPE switch from +INT to -INT and back to +INT. If waveform does not invert and remain stable in both positions, adjust INT TRIG DC LEVEL R53 (fig. 2) until a stable waveform is obtained in both positions.

(13) Remove had and adapters ground the junction of R69 and R70.

(14) Turn TI TRIGGERING LEVEL control until display is stable. If white dot on TI TRIGGERING LEVEL control does not point to zero, loosen setscrew on TRIGGERING LEVEL control and turn knob until white dot points to zero.

(15) Tighten setscrew and remove connection to calibration adapter EXT INPUT.

(16) Position TI controls as listed in (a) through (c) below:

(a) TRIGGERING MODE switch to AUTO.

(b) TRIGGER SLOPE switch to +LINE.

(c) STABILITY control to PRESET.

(17) Connect ac/dc voltmeter (A1) between junction of R214 and SW60B (fig. 2) and chassis ground using two adapters and two leads (B1 and B7).

(18) Turn TI PRESET ADJUST control fully counterclockwise (trace will disappear) and then clockwise until trace just appears on crt. Record ac/dc voltmeter indication.

(19) Turn PRESET ADJUST control clockwise until trace brightens. Record ac/dc voltmeter indication.

(20) Turn TI PRESET ADJUST wiper arm R111 (fig. 4) to obtain an indication on ac/dc voltmeter midway between indications recorded in (18) and (19) above.

b. Adjustments. No further adjustments can be made

14. 5X Magnifier Gain and Sweep Registration

a. Performance Check

(1) Position TI controls as listed in (a) through(c) below:

(a) TRIGGERING MODE (B) switch to AC.

(b) TRIGGERING SLOPE (B) switch to +EXT.

(c) 5X MAGNIFIER switch to ON.

(2) Turn calibration adapter (A3) VARIABLE control fully clockwise.

(3) Connect time-mark generator (A4) MARKER OUTPUT to calibration adapter EXT INPUT, using cable (B5).

(4) Connect time-mark generator TRIGGER OUT to TI B TRIGGER INPUT using cable and adapter (B5 and B2).

(5) Set time-mark generator MARKER SELECTOR switch to .1 mS and TRIGGER SELECTOR switch to 1 mS.

(6) Adjust TI HORIZONTAL POSITION control to align 10th marker behind second vertical graticule line. If 18th time marker does not align within 2 minor divisions of 10th graticule line, perform **b(1)** below.

(7) Position first time marker directly behind center vertical graticule line.

(8) Turn TI 5X MAGNIFIER switch to OFF. If first time marker does not remain directly behind center graticule line, perform **b(2)** below.

TB 9-6625-059-3

b. Adjustments

(1) Adjust MAG GAIN R375 (fig. 4) for one marker per major vertical graticule division on crt (R).

(2) Adjust NORM MAG REGIS R358 (fig. 4) to align first time marker directly behind center graticule line (R).

15. External Horizontal Dc Balance and Deflection Factor

a. Performance Check

(1) Connect TI SAWTOOTH A to calibration adapter (A3) EXT INPUT, using cable (B6).

(2) Turn TI HORIZONTAL DISPLAY switch to EXT X1, STABILITY(A) control fully clockwise, and (A) TRIGGER MODE switch to AC.

(3) Adjust TI HORIZONTAL POSITION control to center the display on TI crt vertical graticule centerline.

(4) Turn TI VARIABLE 10-1 control between stops while observing; for shift of display. If display shifts horizontally, perform **b** below.

(5) Conned; voltage standard (A7) between TI HORIZ INPUT and chassis ground using two leads (B7).

(6) Adjust voltage standard frequency to 1 kHz and amplitude for .0707 volt rms.

(7) Turn TI VARIABLE 10-1 control fully clockwise and adjust STABILITY (A) control for stable display. TI will display at least one major division of horizontal deflection on TI crt.

(8) Adjust voltage standard for .707 volt rms and adjust TI VARIABLE 10-1 control for 10 major divisions of horizontal deflection on TI crt.

(9) Turn TI HORIZONTAL DISPLAY switch to EXT X10. TI crt will display one major division of deflection.

b. Adjustments. Adjust EXT HORIZ DC BAL R317 (fig. 2) while turning VARIABLE 10-1 control throughout its range.

16. External Horizontal Input Compensation

a. Performance Check

(1) Connect square-wave generator (A6) to TI A TRIGGER INPUT and HORIZ INPUT, using cable and termination supplied with square-wave generator and adapters and lead (B2, B3, B4, and B7).

(2) Connect TI SAWTOOTH A to calibration adapter (A3) EXT INPUT, using lead and adapter (B7 and B3).

(3) Position TI controls as listed in (a) through (d) below-

- (a) VARIABLE 10-1 control fully clockwise.
- (b) HORIZONTAL DISPLAY switch to EXT X1.
- (c) TRIGGER SLOPE (A) to EXT
- (d) TIME/CM (A) switch to 10 MILLISEC.

(4) Adjust square-wave generator frequency to 1 kHz and amplitude for 3 centimeters of horizontal deflection on TI crt.

(5) Adjust TI STABILITY and TRIGGERING LEVEL controls for stable display on TI crt. If square-wave display does not have flat tops, perform **b(1)** below.

(6) Turn TI HORIZONTAL DISPLAY switch to EXT X10 and adjust square-wave generator for 3 divisions of horizontal display on TI crt. If square wave does not have flat tops, perform **b(2)** below.

b. Adjustments

- (1) Adjust C330 (fig. 4) for optimum flat top square wave (R).
- (2) Adjust C301C (fig. 2) for optimum flat top square wave (R).

17. TIME BASE B Sweep Rate

a. Performance Check

(1) Connect time-mark generator (A4) to calibration adapter (A3) EXT INPUT, using cable (B5).

(2) Position TI controls as listed in (a) through (c) below:

TB 9-6625-059-3

- (a) HORIZONTAL DISPLAY switch to B.
 - (b) (B) TIME/CM switch to 1 MILLISEC.
 - (c) (B) TRIGGER SLOPE switch to +INT.
- (3) Set time-mark generator to 1 mS markers.
- (4) Adjust TI HORIZONTAL POSITION control to align second marker behind second vertical graticule line on TI crt. If 10th marker is not displayed within ± 1.5 minor divisions of 10th vertical graticule line, perform **b** below.
- (5) Repeat technique of (3) and (4) above for TI switch settings and indications listed in table 5. At each setting, align second or third marker behind second vertical graticule line. At each setting, if either 10th (1/cm) or 19th (2./cm) marker is not displayed within ± 1.5 minor divisions of 10th vertical graticule line, perform appropriate adjustments listed in table 5.

Table 5. Sweep Rate Check TIME BASE B

Time-mark generator MARKET SELECTOR output	Test instrument		
	TIME/CM (B) switch	Markers displayed	Adjustments (fig. 2)
1 mS	2 MILLISEC	2/cm	
5 mS	5 MILLISEC	1/cm	
10 mS	10 MILLISEC	1/cm	
10 mS	20 MILLISEC	2/cm	
50 mS	50 MILLISEC	1/cm	
.1 S	.1 SEC	1/cm	
.1 S	.2 SEC	2/cm	
.5 S	.5 SEC	1/cm	
1 S	1 SEC	1/cm	
.5 mS	.5 MILLISEC	1/cm	
.1 mS	.2 MILLISEC	2/cm	
.1 mS	.1 MILLISEC	1/cm	C260C (R) ¹
50 μ S	50 μ SEC	1/cm	
10 μ S	20 μ SEC	2/cm	
10 μ S	10 μ SEC	1/cm	C260A (R) ²
5 μ S	5 μ SEC	1/cm	
1 μ S	2 μ SEC	2/cm	

¹C260C also interacts with switch positions 50 and 20 μ S, it may be necessary to readjust C260C.

²C260A also interacts with switch positions 5 and 2 μ S, it may be necessary to readjust C260A.

b. Adjustments. Adjust SWP CAL R348 (fig. 2) for display of 1 marker per centimeter (R).

18. TIME BASE A Sweep Rate

a. Performance Check

- (1) Position TI controls as listed in (a) through (c) below:
 - (a) HORIZONTAL DISPLAY switch to A.
 - (b) (A) TRIGGER SLOPE switch to +INT.
 - (c) (A) TIME/CM switch to .1 MILLISEC.
- (2) Set time-mark generator (A4) to 10 μ S markers.
- (3) Turn TI 5X MAGNIFIER switch to ON.
- (4) Position first time marker behind center vertical graticule line on TI, using HORIZONTAL POSITION control.
- (5) Turn TI TIME/CM switch to 50 μ SEC. If first time marker does not remain behind vertical graticule line, perform **b** below.
- (6) Turn TI 5X MAGNIFIER switch to OFF.
- (7) Repeat technique of (2) above for TI and time-mark generator switch settings and indications listed in table 6. At each setting, align second (1/cm) or third (2/cm) marker behind second vertical graticule line. At each setting, if either 10th (1/cm) or 19th (2/cm) markers are not displayed within ± 1.5 minor divisions of 10th vertical graticule line, perform adjustments listed in table 6.

Table 6. Sweep Rate Check TIME BASE A

Time-mark generator output	Test instrument		
	TIME/CM (A) switch	Markers displayed	Adjustments
.1 mS	.2 MILLISEC	2/cm	
.5 mS	.5 MILLISEC	1/cm	
1 mS	1 MILLISEC	1/cm	R160Z (fig. 2) (R)
1 mS	2 MILLISEC	2/cm	
5 mS	5 MILLISEC	1/cm	
10 mS	10 MILLISEC	1/cm	
10 mS	20 MILLISEC	2/cm	
50 mS	50 MILLISEC	1/cm	
.1 S	.1 SEC	1/cm	
.1 S	.2 SEC	2/cm	
.5 S	.5 SEC	1/cm	
1 S	1 SEC	1/cm	
1 S	2 SEC	2/cm	

Table 6. Sweep Rate Check TIME BASE A - Continued

Time-mark generator output	Test instrument		
	TIME/CM (A) switch	Markers displayed	Adjustments
5 S	5 SEC	1/cm	
50 μ S	50 μ SEC	1/cm	
10 μ S	20 μ SEC	2/cm	
10 μ S	10 μ SEC	1/cm	C160E (fig. 2) (R)
5 μ S	5 μ SEC	1/cm	C160C (fig. 2) (R)
1 μ S	2 μ SEC	2/cm	C160C (R)
1 μ S	1 μ SEC	1/cm	C160C (R)
.5 μ S	.5 μ SEC ¹	1/cm	C160A ¹ (fig. 2) (R)
.1 μ S	.2 μ SEC ²	2/cm	
.1 μ S	.1 μ SEC ¹	1/cm	C375 ³ (fig. 4) (R) C348 (fig. 2) (R)
50 nS	.1 μ SEC ³	2/cm	C364, C384 ⁴ (R) (fig. 4)

¹Connect X generator TRIGGER OUT of TI TRIGGER INPUT, using cable (B6). Turn TRIGGER SLOPE switch to +EXT. Set marker for 10 μ S trigger output.

²Position second marker to second line on graticule.

³C375 affects linearity only in first part of display. Reaction exists between C348 and both C160A and C160C. Adjustments of C348 and C160A should be repeated several times for optimum linearity with correct timing, after which C160C should be readjusted, if necessary.

⁴It may be necessary to readjust C375 slightly for best linearity possible.

b. Adjustments. Adjust C330 (fig. 4) for no shift of marker as TIME/CM switch is turned from .1 MILLISEC to 50 μ SEC (R).

19. TIME BASE A Sweep Length

a. Performance Check. Turn TI TIME/MC switch to 1 MILLISEC. If trace on TI crt is not 10.5 centimeters in length, perform **b** below.

b. Adjustments. Adjust SWEEP LENGTH R176 (fig. 4) for sweep length of 10.5 centimeters of horizontal deflection.

20. TIME BASE B Sweep Length

a. Performance Check

- (1) Position TI controls as listed in (a) through (c) below.
 - (a) HORIZONTAL DISPLAY switch to B.
 - (b) TIME/CM switch to 1 MILLISEC.
 - (c) LENGTH control fully counterclockwise.
- (2) Adjust TI STABILITY control for a free-running sweep.

(3) Turn TI LENGTH control fully clockwise observing crt. Sweep length will change from approximately 3.5 to 10.5 centimeters.

b. Adjustments. No adjustments can be made.

21. Lockout Level

a. Performance Check

(1) Set TI HORIZONTAL DISPLAY switch to 'A' DEL'D BY 'B' and (B) STABILITY control fully clockwise.

(2) Set (A) TIME/CM switch to .1 MILLISEC and slowly adjust (A) STABILITY control until sweep first).

(3) Connect test oscilloscope (A5) to TI pin 3 of V133, using probe (B8) with dc coupling.

(4) Adjust test oscilloscope for 4 divisions of vertical deflection on test oscilloscope. If square-wave portion of display does not indicate 2.4 divisions and sawtooth is not 1.6 divisions in amplitude on test oscilloscope crt, perform **b** below.

b. Adjustments. Adjust LOCKOUT LEVEL ADJ R125 (fig. 4) until square-wave portion on test oscilloscope crt is 2.4 divisions and sawtooth is 15 divisions in amplitude.

22. Delay Start and Delay Stop

a. Performance Check

(1) Position TI controls as listed in (a) through (d) below:

(a) HORIZONTAL DISPLAY switch to 'B' INTENSIFIED'.

(b) TIME/CM (A) switch to 50 μ SEC.

(c) TRIGGER SLOPE (A) switch to +INT.

(d) DELAY-TIME MULTIPLIER control to 1.00.

(2) Connect time-mark generator (A4) to calibration adapter (A3) EXT INPUT, using cable (B5).

(3) Set time-mark generator to 1 mS markers.

(4) Adjust TI TRIGGERING LEVEL (B) and STABILITY (B) controls for stable display on TI crt. Adjust TI HORIZONTAL POSITION control to zone first time marker on first vertical graticule line.

TB 9-6625-059-3

(5) Turn TI STABILITY (A) control fully clockwise. If intensified portion of sweep does not start at second time marker, perform **b(1)** below.

(6) Turn TI DELAY-TIME MULTIPLIER control to NO. If intensified portion of sweep does not start at 10th time marker, perform **b(2)** below.

(7) Turn TI HORIZONTAL DISPLAY switch to 'A' DEL'D BY 'B'. Leading edge of time marker will be at start of trace.

(8) Turn TI DELAY-TIME MULTIPLIER control to 1.00. If leading edge of time marker is not at start of trace, perform **b(3)** below.

b. Adjustments

(1) Adjust DELAY START R436 (fig. 2) until intensified portion sweep starts at second time marker.

(2) Adjust DELAY STOP R432 (fig. 2) until intensified portion of sweep starts at 10th time marker.

(3) Readjust R432 if leading edge is not at start of at may be necessary to repeat **b(4)** through (8) above.

23. Rise Time

a. Performance Check

(1) Turn TI TIME/CM (A) switch to .1 μ SEC and HORIZONTAL DISPLAY switch to A.

(2) Turn calibration adapter (A3) TEST FUNCTION switch to +PULSE and REPETITION RATE switch to HIGH (500 kHz).

(3) Adjust calibration adapter AMPLITUDE control for 4 centimeters of vertical deflection on TI crt.

(4) Turn TI 5X MAGNIFIER switch to ON.

(5) Measure rise time, using standard rise-time technique. Rise time will 12 nanoseconds or less.

b. Adjustments. No adjustments can be made.

24. Power Supply

a. Performance Check

NOTE

Do not perform power supply check if all other parameters are within tolerance.

(1) Turn calibration adapter (A3) TEST FUNCTION switch to GAIN SET.

(2) Connect ac/dc voltmeter (A1) between chassis ground and -150 V test point (fig. 2), using leads supplied with ac/dc voltmeter or two adapters and two leads (B1 and B7). If ac/dc voltmeter does not indicate between -147 and -153 volts dc, perform **b(1)** below

(3) Repeat technique of (2) above, using test points and indications listed in table 7. Ac/dc voltmeter will indicate within limits s specified.

Table 7. Power Supply Accuracy Values

Test point (fig. 2)	Ac/dc voltmeter indication (vdc)	
	Min	Max
+100V	+98	+102
+225V	+220.5	+229.5
+350V	+343	+357
+500V	+490	+510

(4) Turn calibration adapter TEST FUNCTION switch to HIGH LOAD and repeat technique of (2) and (3) above.

(5) Connect ac/dc voltmeter between HIGH VOLTAGE TEST POINT R847 (fig. 4) and chassis ground, using high voltage probe If ac/dc voltmeter does not indicate between -1325 and -1375 volts dc, perform **b(2)** below.

b. Adjustments

(1) Adjust R616 (fig. 2) for best in-tolerance compromise of voltages measured in **a(2)** and (3) above (R).

(2) Adjust R840 (fig. 2) for ac/dc voltmeter indication of -1350 volts dc (R).

25. Final Procedure

a. Deenergize and disconnect all equipment and replace protective covers on TI.

b. In accordance with TM 38-750, annotate and affix DA Label 80 (US Army Calibrated Instrument). When the TI receives limited or special calibration, annotate and affix DA Label 163 (US Army Limited or Special Calibration). When the TI cannot be adjusted within tolerance, annotate and affix DA Form 2417 (US Army Calibration System Rejected Instrument).

TB 9-6625-059-35

By Order of the Secretary of the Army:

FRED C. WEYAND
General, United States Army
Chief of Staff

Official:

PAUL T. SMITH
Major General, United States Army
The Adjutant General

Distribution:

To be distributed in accordance with DA Form 12-34A, (qty rqr block No. 75), requirements for Calibration Procedures Publications.

US GOVERNMENT PRINTING OFFICE: 1976-665668/449

PIN: 010304-000